

JCP.401

Sidepost Crank Lift



OWNER'S MANUAL

IMPORTANT :

Please read this entire manual before installing or operating your umbrella.

DIAGRAM & PARTS LIST

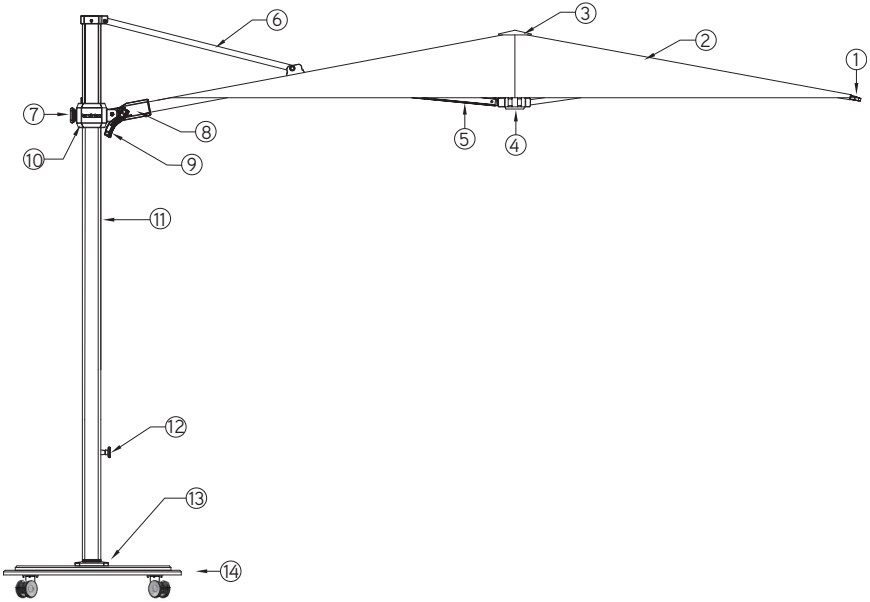

- | | |
|---------------------------------|---|
| 1. Self-Locking Canopy Fastener | 9. Crank Handle |
| 2. Canopy | 10. Slider Car |
| 3. Finial | 11. Mast |
| 4. Lower Hub | 12. Rotation Knob |
| 5. Rib | 13. Internal Mast Stem Cover |
| 6. Main Arm | 14. JCB401 Base with Wheels (sold separately) |
| 7. Adjustment Knob | 15. Strap (not shown) |
| 8. Open/Close Mechanism | 16. Protective Cover (not shown) |

SPECIFICATIONS

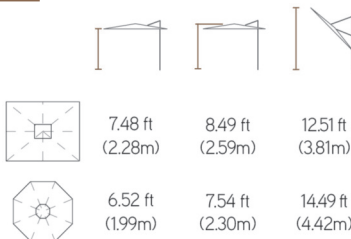

ASSEMBLY INSTRUCTIONS

Two-person team is recommended for assembly

Installing Internal Stem

1. Lay umbrella on soft clean surface. Attach finial to canopy structure.
2. Pull and quarter turn rotation knob counter clockwise to unlock internal stem from mast. Remove internal stem from bottom of mast.
3. Install internal stem onto steel base or mount plate with supplied 4 bolts and tighten using hex wrench. **NOTE:** Do not use power drill. May cause damage to base.
4. Slide internal mast stem cover over internal stem.

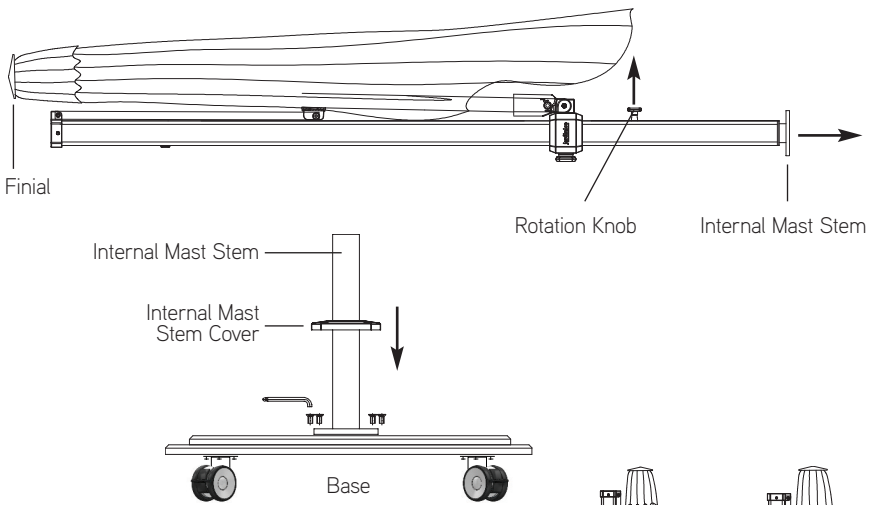

5. Using a two-person team, carefully lift umbrella and insert bottom of mast onto internal mast stem. **NOTE:** Mast will stop when 2cm away from base plate. Pull and quarter turn rotation knob to unlock. Mast will continue to slide down internal mast stem.
6. It may be necessary to gently shake or slightly turn mast to ensure rotation knob locates internal mast stem hole and is attached to internal mast stem.

You are now ready to operate your umbrella!

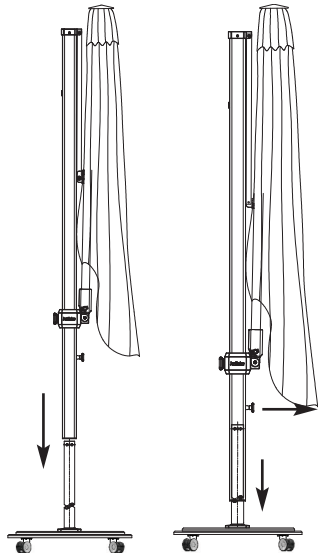

OPERATING INSTRUCTIONS

Remove all packaging from umbrella.

To Open Canopy

1. Remove the strap that holds the canopy structure to the mast when in the closed position. Take note of the “parachute” folding method used to fold the canopy when closed. (See page 7 to properly fold canopy.)
2. Slightly loosen arms. **CAUTION: NEVER FORCE THE ARMS.** If you experience any resistance, make sure all arms are freed manually to facilitate opening.
3. Turn adjustment knob counter clockwise and slide car half way up mast. Tighten knob by turning clockwise to secure in place.
4. Insert crank handle into “Close / Open” socket and crank handle clockwise until canopy is completely open.
5. Turn adjustment knob counter clockwise and slide car upward until umbrella is at a horizontal shade position. Turn adjustment knob clockwise to secure in place.

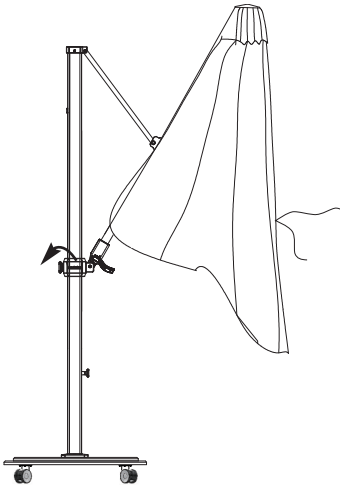

Remove Strap,
Turn Adjustment Knob,
Slide to Mid Mast

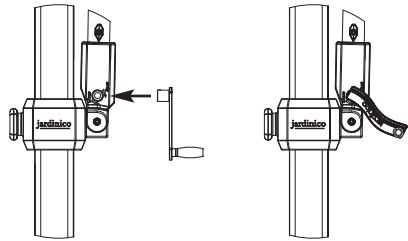

Insert Crank Handle into “Close/Open” Socket

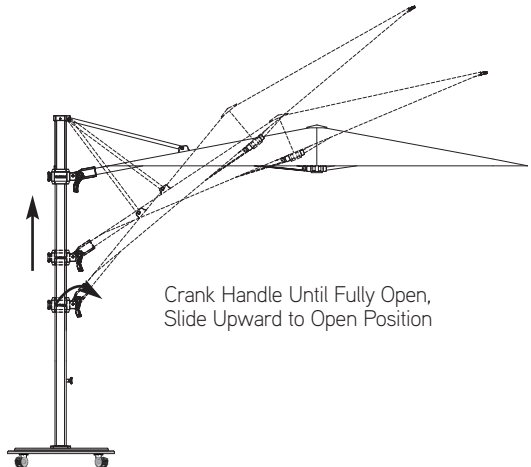

Crank Handle Until Fully Open,
Slide Upward to Open Position

To Tilt Canopy Front to Back

1. Turn adjustment knob counter clockwise and slide car upward or downward until desired tilt degree of shade is reached. Tighten knob by turning clockwise to secure in place.
NOTE: Do not use tilt function during winds.

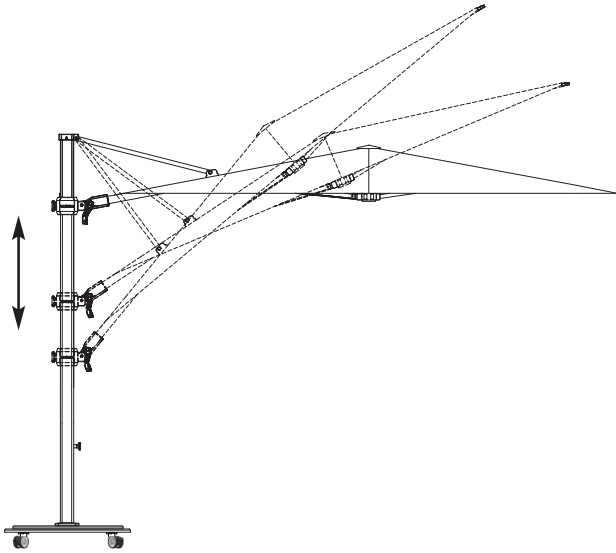

To Rotate 360°

1. There are (12) 30° locking rotating positions. Pull and quarter turn rotation knob counter clockwise. Rotate mast to one of the 12 preset positions. Turn rotation knob clockwise to secure in place.
NOTE: Do not use rotating function during winds. Doing so may cause damage to your umbrella.

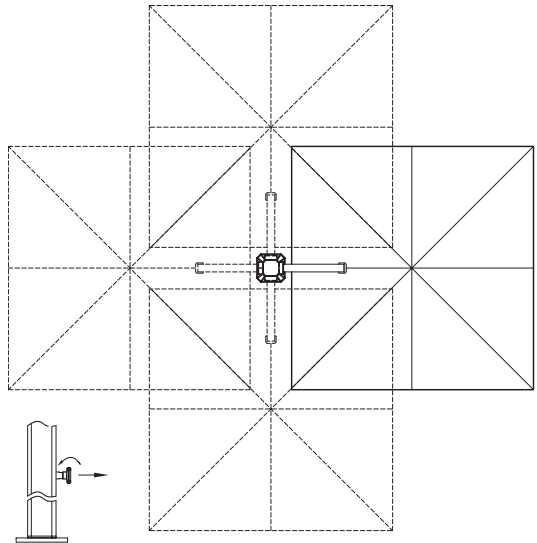

To Close Canopy

1. Turn adjustment knob counter clockwise and crank handle counter clockwise. Canopy will close and umbrella will slide down mast simultaneously by operating the crank handle.
NOTE: Stop turning crank when umbrella is fully closed. Failing to do so may cause damage to umbrella.
2. Turn adjustment knob clockwise to secure umbrella in place.

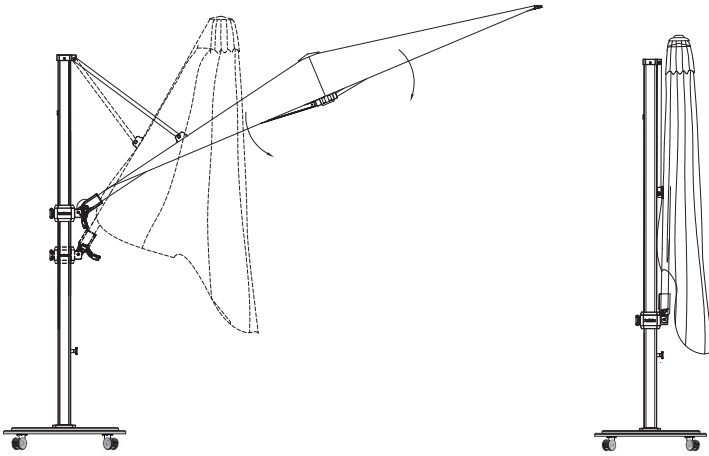

To Properly Fold Canopy

The 100% solution dyed canopy will last longer if you fold it as it was packed and shipped. This technique is similar to the way a parachute is folded and is especially important when folding the canopy for seasonal storage or when left in the closed position for an extended period of time.

Using this technique at all times will significantly extend the life of the canopy.

1. When the canopy has been fully lowered, stand in front of the canopy structure and begin the folding process by pulling out two panels opposite the mast.
2. Once rolled tight, pull adjacent panels out one at a time and fold to the center, alternating sides until all the panels have been pulled out from the arms and folded into the center.
3. Wrap provided strap around canopy to secure.
4. When not in use, cover umbrella with provided protective cover.

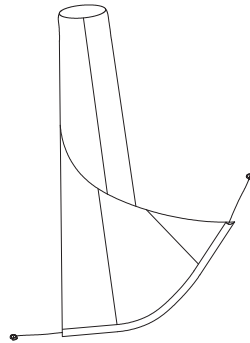

Protective Cover

MAINTENANCE :

MAINTAINING THE JARDINICO FRAME AND FITTINGS

1. Hose mast and frame with water periodically, more often if installation is in a salty or industrial environment.
2. Inspect the installation fittings, mount bolts, rib spacers, etc. on a regular basis and tighten if necessary.
3. Seaside and indoor pool use: Due to demands of both of these environments, Jardinico recommends weekly or biweekly cleaning with mild soap and water to remove the concentrated deposits and protect the powder coat finish.

MAINTAINING THE JARDINICO CANOPY FABRIC

1. Clean up spills and stains right away. Spills can be removed by using a clean absorbent cloth.
2. For general maintenance, use a soft brush to remove dust and dry soil. Wash down with clean, warm water (i.e., garden hose) every so often to avoid dirt becoming ingrained. Allow the fabric to air dry before closing the canopy.
3. If a thorough cleaning is necessary, sponge over the fabric using a mild soap solution (2% solution). Rinse well with plenty of water to remove all soap residue.
4. Never use detergents, cleaning fluids or solvents.
5. Please visit the fabric websites for more details: www.jardinicousa.com or www.sunbrella.com
6. Use protective canopy cover during storage or when not in use.

GENERAL GUIDELINES

1. Jardinico highly recommends that no umbrella, regardless of size or weight, ever be left unattended in the open position. In windy conditions, it is further recommended that umbrellas be closed, removed from their base, and stored, or laid horizontally. This will reduce the risk of damage to your umbrella, furniture, and other belongings or property. To ensure stability of your umbrella, please observe proper placement, and use sufficient weight (base). This catalog contains minimum recommendations for necessary weight; but this can vary, depending on the conditions in your particular area.
2. NOTE: Wind damage (or any damage caused by acts of nature) is not covered under warranty.
3. Sufficient base weight must be used to secure umbrellas at all times. Please see individual product pages for recommended minimum weight requirements for free-standing applications.

WARRANTY:

Jardinico® manufactures all its shade styles from the finest aluminum alloys to ensure the strength, durability, and integrity of each and every style. We pride ourselves as a totally vertical operation. This means that we manufacture and produce over 90% of the components used in our products from the raw state. We can monitor every stage of the manufacturing process and maintain a consistent level of quality.

Our goal is that each and every Jardinico style will exceed your expectations.

Our **Limited Warranty** is outlined below. **NOTE: Wind damage is not covered under any manufacturer's warranty.**

5 Year Limited Warranty includes the mast, boom, head fitting, elbow, center pole/sidepost, arms, ribs, top and bottom hub and stainless steel hardware only. If there is damage under the warranty, Jardinico will replace and/or repair any item listed in this category at its discretion. Labor charges are not covered under this limited warranty.

5 Year Limited Warranty covers the wheels, powder coat finish, rust and corrosion on all bases. If the powder coat finish flakes, bubbles, peels or loses color; Jardinico will re-finish or replace the defective base at its discretion. Normal wear and tear is not covered under this limited warranty. Labor charges are not covered under this limited warranty.

5 Year Limited Warranty applies to Sunbrella® furniture grade fabrics. Visit www.sunbrella.com for more details. Labor charges are not covered under this limited warranty.

1 Year Limited Warranty covers accessories and protective covers.

What is NOT covered:

Failure caused by unreasonable or abusive use, or failure caused by neglect of reasonable and necessary care, and any modification to product are not covered by this warranty.

Additionally, acts of nature (including but not limited to wind, hurricanes, tornadoes and storms) are not covered by this warranty.

Wind Damage:

Jardinico highly recommends that no umbrella, regardless of size or weight, ever be left unattended in the open position. In windy conditions, it is further recommended that umbrellas be closed, removed from their base, and stored, or laid horizontally. This will reduce the risk of damage to your umbrella, furniture, and other belongings or property. To ensure stability of your umbrella, please observe proper placement, and use sufficient weight (base) or permanent mount.

WIND DAMAGE IS NOT COVERED UNDER OUR LIMITED WARRANTY.

(Warranty continued on next page)

WARRANTY:

Seaside and Indoor Pool Usage:

CAUTION: Seaside and indoor pool use, salt & chlorides can accumulate on the powder coat finish, leading to finish failure. Failure or neglect to make needed cleanings may cause paint to blister, and such failure will void limited warranty.

Irregularities in Production Process:

The possibility of "Irregularities" in the product surface may occur during the production process. However, these irregularities do not reduce the quality of the product. Jardinico monitors every stage of production to ensure a clean and consistent appearances on every part.

Rust:

Rust is a natural part of the aging process of all steel based materials and is therefore NOT considered a defect. Steel bases are designed to require minimum maintenance. Bases should be kept clean. Do not let dirt build up on the bases. Never leave bases standing in water. To keep your bases looking their best, you may wish to store them when not in use for an extended period of time.

It is our policy to continuously improve designs, materials and manufacturing methods in order to provide you with the finest products. Therefore, variations in specifications, materials, prices, styles and finishes may be made without notice.

Those filing warranty claims will be responsible for all shipping, handling, and freight charges on all claims to Jardinico in Baldwin Park, CA. All warranty claims must be submitted with the original proof of purchase, date of purchase, name of dealer, and the description of the damage. The Jardinico warranty is not transferable. Jardinico reserves the right to repair, replace, and/or redesign any product that is returned under a warranty claim.

For questions, contact Customer Service: 626-338-8810 or info@jardinicousa.com



13401 Brooks Drive, Baldwin Park, CA 91706
626.338.8810 | 626.338.8816 fax

jardincousa.com | info@jardincousa.com